

HYPERCUTTER

Range Øe 1524-2540 mm (60"-100")



GBC HYPERCUTTER è il modello di tagliatubi a freddo dedicato ad esecuzione di taglio e smusso su tubazioni di diametro rilevanti. Utilizzabile sia in officina sia su pipeline è esclusivamente equipaggiata con motore idraulico.

GBC HYPERCUTTER is the model of pipe cold cutting and beveling machine conceived for cutting and beveling pipes with relevant diameters. It is suitable for heavy duty jobs in the workshop as well as on the field and it is supplied exclusively in hydraulic version.

La macchina viene fornita con motorizzazione idraulica specifica per lavorazioni su grandi diametri. The machine is supplied with specific hydraulic motor for job on relevant diameters.

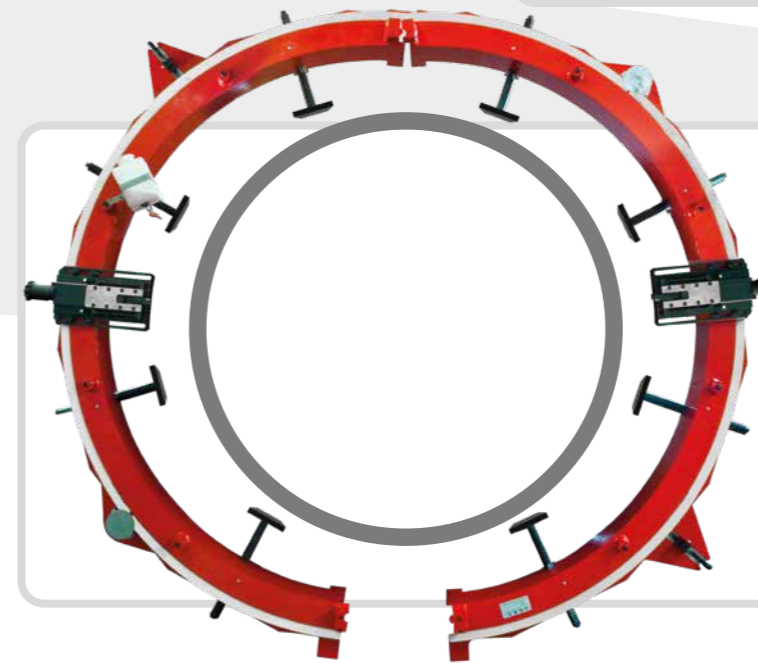

Concepita per lavorare in esterni su pipeline, il corpo macchina si apre permettendo di installare la macchina in qualsiasi punto della linea tubi
Designed for onsite applications in the pipeline field, the machine has a clamshell frame that allows the unit to be placed anywhere along the pipelines.

Fissaggio ad 8 punti di bloccaggio regolabili separatamente dotati di ampie piastre di contatto.

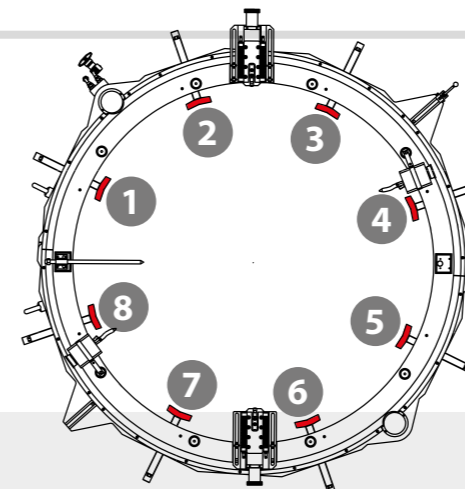

Locking system with 8 independent wide pads.

CAMPO DI LAVORO: tubi da 60" a 100"
PRESTAZIONI: taglio e smusso di tubi a freddo
MATERIALI: acciai al carbonio, inox, duplex, inconel, altri
ALIMENTAZIONE: idraulica

RANGE: 60" to 100"
FUNCTIONS: pipe cold cutting, beveling, facing, counterboring
MATERIALS: carbon steel, stainless steel, duplex, inconel, others
POWER: hydraulic

HYPERCUTTER

Range Øe 1524-2540 mm (60"-100")



Tutte le ganasce di bloccaggio riportano l'incisione dei diametri tubo lavorabili per velocizzare il posizionamento macchina.

The locking jaws are engraved with a linear scale for a quick and easy setup of the unit.

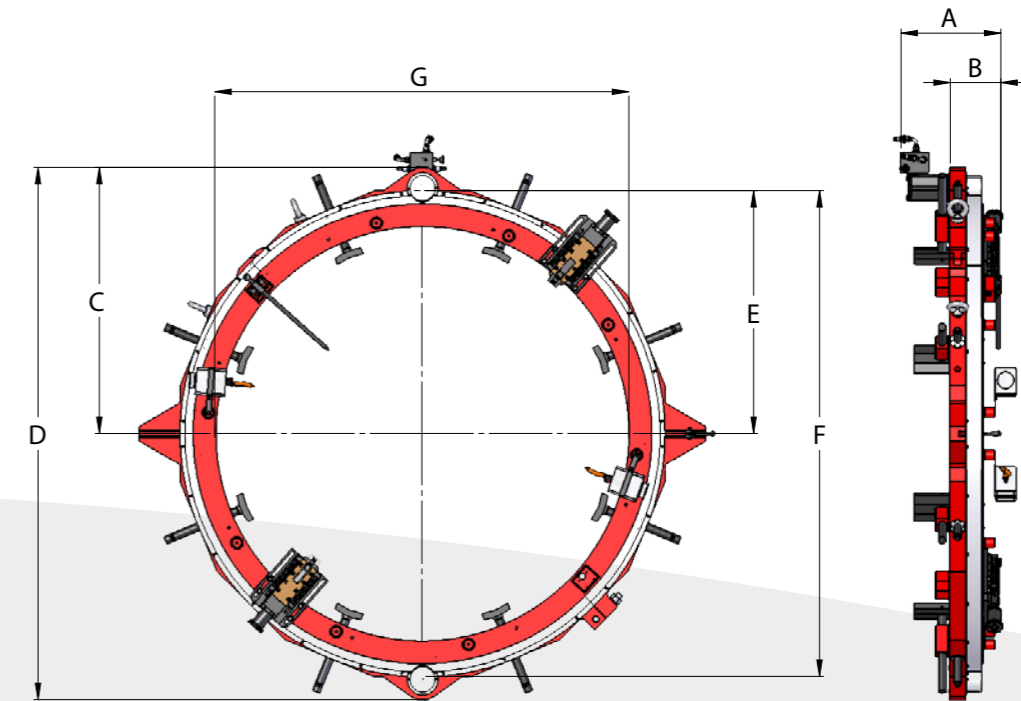
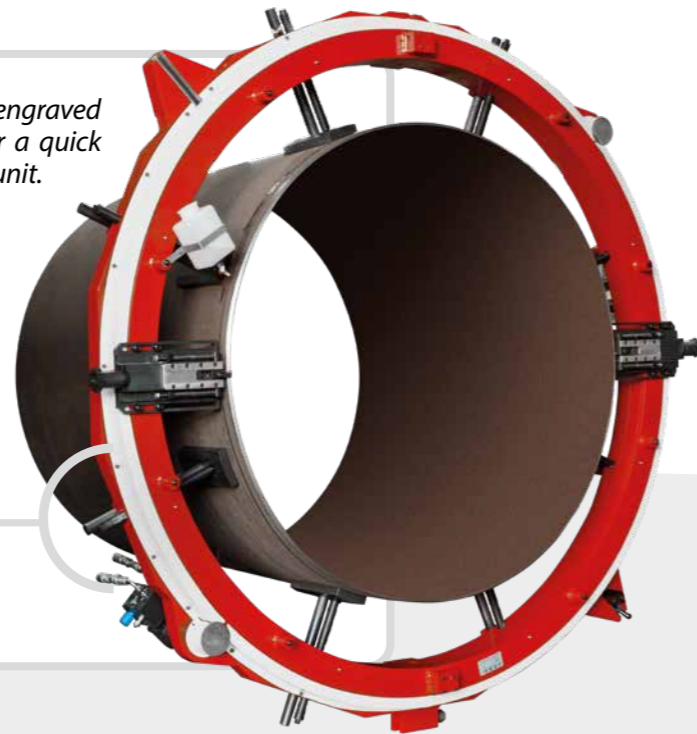
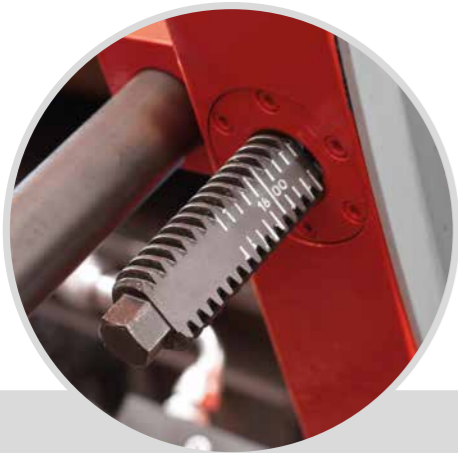

Portautensili, con sistema di copiatura per compensare irregolarità e ovalizzazioni, dotati di dispositivo per l'avanzamento automatico della lavorazione



The tool holders have a copier system that follows the pipe OD profile to compensate the bevel offset on out of round pipes.



UTENSILI - TOOLS

Ampia gamma di utensili utilizzabili per taglio e smusso (standard e combinato), per tutte le tipologie di materiali e progettabili su misura in base alle specifiche del cliente.

Wide range of tools, for cutting and for beveling (standard and compound) for all the type of materials and opportunity to design them according to the customer's specifications.

DIMENSIONI E INGOMBRI - DIMENSIONS AND SIZES

Modello Model	Alim. Supply	Dim. A (mm)	Dim. B (mm)	Dim. C (mm)	Dim. D (mm)	Dim. E (mm)	Dim. F (mm)	Dim. G (mm)
HC60-80	Hydr.	485	245,5	1395,25	2790,5	1290,25	2580,5	2220
HC80-100	Hydr.	485	245,5	1670	3340	1534	3068	2688

DATI TECNICI - TECHNICAL FEATURES

		HC60-80	HC80-100
Capacità di bloccaggio (Ø E) Locking range (Ø OD)	mm	1524	2032
	min max	2032	2540
	inches	60	80
	min max	80	100
Corsa Portautensile Toolholder stroke	mm	110	110
	inches	4,33	4,33
Avanzamento radiale Feeding Pitch	mm	0,125	0,125
	inches	0,005	0,005
Peso macchina Machine weight	Kg	2395	2689
Potenza motore idraulico Hydraulic motor power	Hp	20,4	20,4
	kW	15	15
Pressione max. centralina GBC Max. GBC power pack pressure	bar	160	160
	psi	2320,6	2320,6
Erogazione olio Oil flow	L/min	66	66
	cfm	2,33	2,33
Coppia massima corona Max. ring torque	Nm	20000	28000
Velocità a vuoto Idle speed	gg/min	7	5
	(rpm)		